

OPERATION AND SERVICE MANUAL

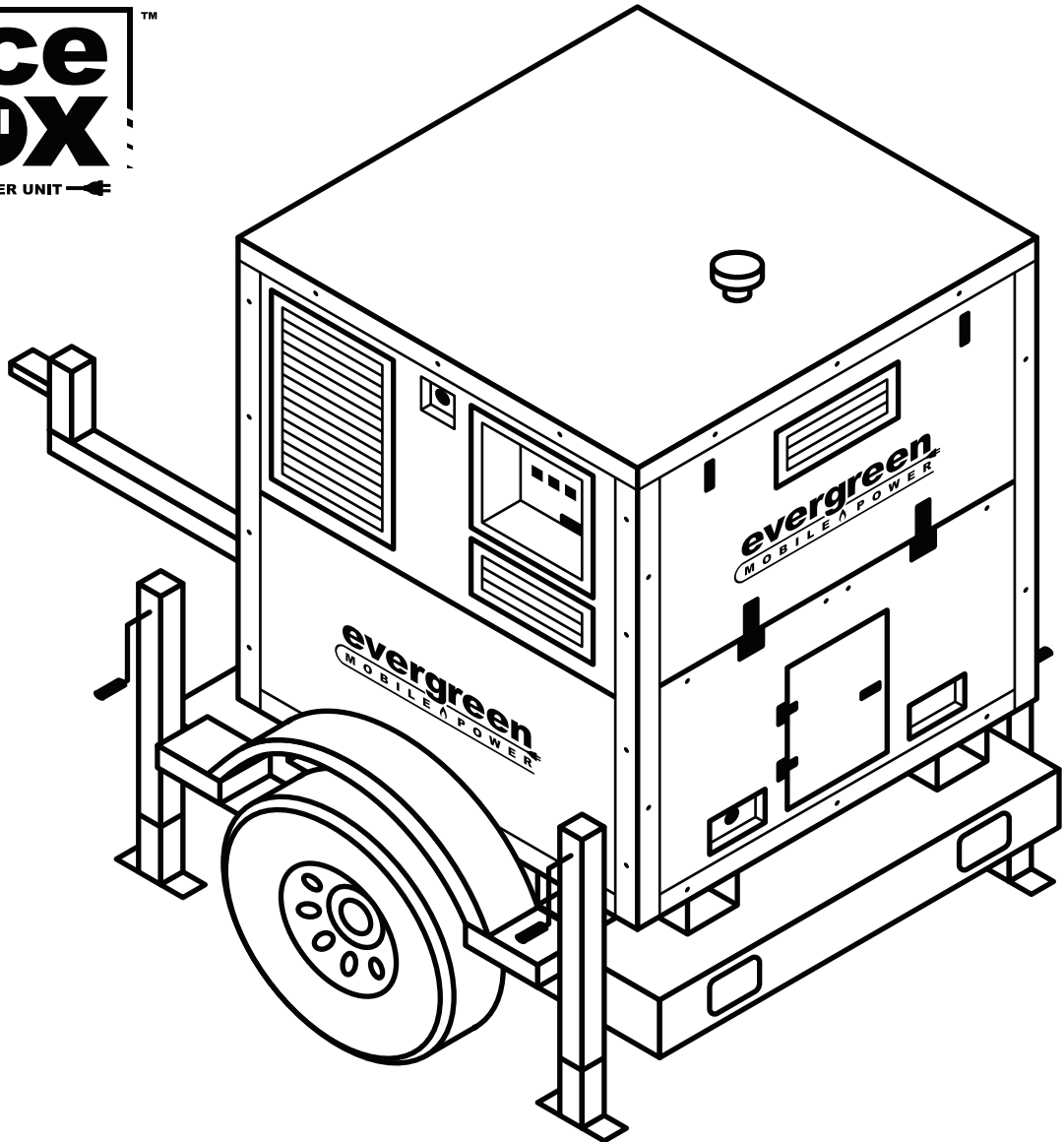

© COPYRIGHT 2024 , ENERGY TREE, LLC.



A Energy Tree, LLC Company
2009 West Osage St, Pacific, MO 63069
844-KILOWAT (844-545-6928)
www.evergreenmobilepower.com

CALIFORNIA PROPOSITION

65 WARNING

WARNING: This product contains chemicals known to the State of California to cause cancer and birth defects or other reproductive harm.

For more information: www.P65Warnings.ca.gov

TABLE OF CONTENTS

Table of Contents	3
Safety Protocols	4-5
Quick Start Guide	6
JuiceBox Specifications	7
Trailer Specifications	8
Orientation	9-12
Fuel Tanks	13
External Fuel Connections	14
Engine Bay	15
Battery Switch	16
Fuel Source Selector Switch	17
Control Module	18-20
Electrical Enclosure	21
Power Distribution Panels	22-26
Electrical Grounding	27
Fault Codes	28-29
Maintenance	30-33
Optional Equipment	34-36
Wiring Diagrams	37-48
Product Warranty	49-50

SAFETY PROTOCOLS

ATTENTION:

We created the JuiceBox™ as an easy and safe product to use for mobile power needs, but certain aspects of its operation can be dangerous if proper precautions are not followed. This manual should be read in its entirety (we know, not fun but informative!) prior to operating the JuiceBox™.

Failure to do so could lead to serious injuries or even death. We certainly don't want that so PLEASE read this manual!

General Safety

The JuiceBox™ is an electrical device and all laws and regulations in your area that are applicable to mobile electric equipment, gaseous engines, electrical connections, and all other aspects that fall under the use of the JuiceBox™ should be followed.

That means we do not know where, how, or why you are using the JuiceBox™. We trust that you have taken care of the fine details that may apply to use of the JuiceBox™ where you are at. If you haven't, please do that.

Things you should know (but we'll mention them anyway) - These may seem obvious but for sake of checking the boxes, you should not operate the JuiceBox™ if:

- You are not wearing or using proper safety equipment (Personal Protection Equipment).
 - You are under the influence of drugs and alcohol (must be said for the stupid people).
 - You are attempting to connect additional equipment and accessories that are not approved or not safe for use with the JuiceBox™.
- ### Additional Precautions
- These may not be as obvious, but we want to make sure to mention them:
- **DO NOT** operate your JuiceBox™ in areas where the exhaust of the machine can be inhaled by humans (oh and dogs, we care about dogs. Cats not as much).
 - There could be areas of the JuiceBox™ that get **hot** and **should NOT be touched**. These are marked as such but just figure any portion of the engine bay or exhaust could be hot.
 - The JuiceBox™ uses propane (LPG) or in some cases natural gas. These are safe and stable when used in accordance with regulations that cover its use. If you are not qualified to work on these systems, please consult a qualified technician or if you need help finding a qualified service center for the fuel system on your machine, please contact us at **844-545-6928** or through our website **www.evergreenmobilepower.com** and we will help find someone in your area to help. Failure to do this could result in damage to your JuiceBox™, or physical injury or even death. Please be safe!
- You are not qualified to do so.
 - You have not read this manual in its entirety.
 - You have not consulted local, state, and federal laws or regulations governing the use of this product.

SAFETY PROTOCOLS

- The JuiceBox™ is an electrical generator and as that term states, the unit makes electricity. Therefore, only qualified electricians should make the electrical connections to the JuiceBox™. There is an **electrical shock hazard** present when the unit is running so extreme caution should be used when interacting with a running JuiceBox™.
- When changing the oil in the JuiceBox™, take precautions to avoid contact with the hot oil as this can cause **severe burns**. Allow enough time for the engine to cool prior to doing any service on the unit.
- Inspect all cabling for damage prior to connecting to the JuiceBox™. Yes, seems logical but not everyone does this and it can cause bodily injury or death.
- **DO NOT** attempt to connect the JuiceBox™ to a utility or any other existing electrical grid.
- The JuiceBox™ should never be operated without all of its safety guards. This includes the two (2) electric power distribution panels, propane vent cap, engine baffles, exhaust silencer, exhaust flap door, engine bay baffles, and the exhaust shield.
- If there is an unexpected noise or smell or smoke coming from the JuiceBox™, turn the machine off and have it looked at by a qualified, trained, service center otherwise severe damage to the machine could occur. That would not be cool.

QUICK START GUIDE

Steps to Start The Unit

1. Check fuel tank level (or external fuel supply)	13-14
2. Check engine oil level (add if needed)	15
3. Check all electrical connections	21
4. Check circuit breakers are in off or open position	12
5. Open battery door to access the battery switch	9
6. Turn battery switch to ON	9
7. Turn engine start switch to ON	12
8. Verify correct voltage on meter or generator controller	9
9. Close main circuit breaker and other breakers (if equipped)	12

Steps to Shut Down The Unit

1. Open main circuit breaker	12
2. Turn engine start switch to OFF	12
3. Turn battery switch to OFF	9









Placing The Unit

The discharge of all engine exhaust and cooling air from the machine exits from the engine side of the generator (see page 10). If your generator is mounted on a trailer, the engine side of the generator could be facing the tongue of the trailer or the rear of the trailer. In either case, be sure to face the engine side of the generator away from pedestrian traffic areas, or areas where people might gather. Also make sure there are no obstructions within 5 feet of any side of the generator. Walls or any other solid objects placed too close to the generator could cause excessive noise and heat reflections which could damage the generator or increase its noise output.

The generator unit should be leveled within + / - 5 degrees from the center of any top edge. A +/- 5 degree difference translates into one side of the generator being approximately four inches (4") higher or lower than any other side. If the generator is not level, the engine may not receive proper lubrication and cause damage to the engine.

JUICEBOX™ SPECIFICATIONS

Table 1. JuiceBox Specifications

Weight – Dry	1,776 lbs	
Weight – Wet	2,050 lbs	
Exterior Dimensions	50" L x 50" W x 54" H	
Fuel Capacity	64 US Gallon LPG Only	
Engine Displacement	1.0L Air-Cooled	
Fuel Consumption	10% Load - 1 gph 50% Load - 2 gph 100% Load - 3 gph	
Engine Oil Capacity – Standard	2.5 qts	
Engine Oil Capacity – Extended Run*	2.0 gals*	
Electrical Output	25kW at 120/208 V 60 hz	

*Indicates Optional Equipment

TRAILER SPECIFICATIONS

Table 2. Trailer Specifications

Weight	575 lbs	
Exterior Dimensions	68" L x 74" W	
Hitch	2" Ball or Pintle*	
Wiring	7 Pin RV Style 4 Pin Flat*	
Axle	3,500 lbs Torsion Type (No Brakes)	
Wheels	15" 5 Lug	
Tires	205 75R 15 Radial Trailer Duty	

*Indicates Optional Equipment

Consult tire manufacturer for tire wear information. Tires should be inflated to 50 psi. Check lug nut for proper tightness (90-120 ft lbs). Never tow a JuiceBox™ over 55 mph and obey all regulations that apply to your area for road use.

ORIENTATION – FRONT

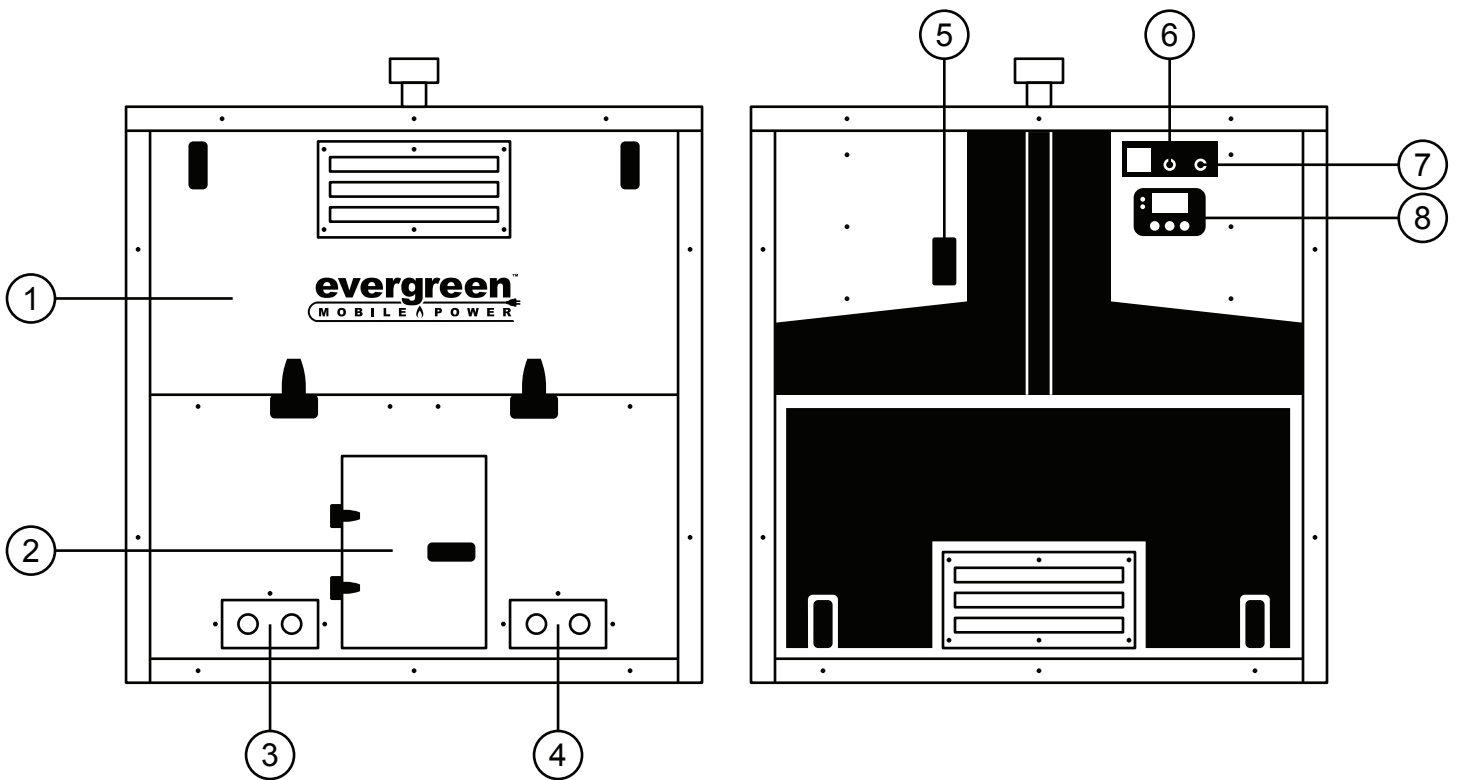

1	Storage Area
2	Battery Access and Battery Switch
3	External Fuel Connection and Natural Gas Connection (if equipped)
4	Ground Lug and Water Heater Connections (if equipped)
5	Fuse/Relay
6	Fuel Source Selector Switch
7	Fine Voltage Adjustment
8	Control Module

ORIENTATION – REAR

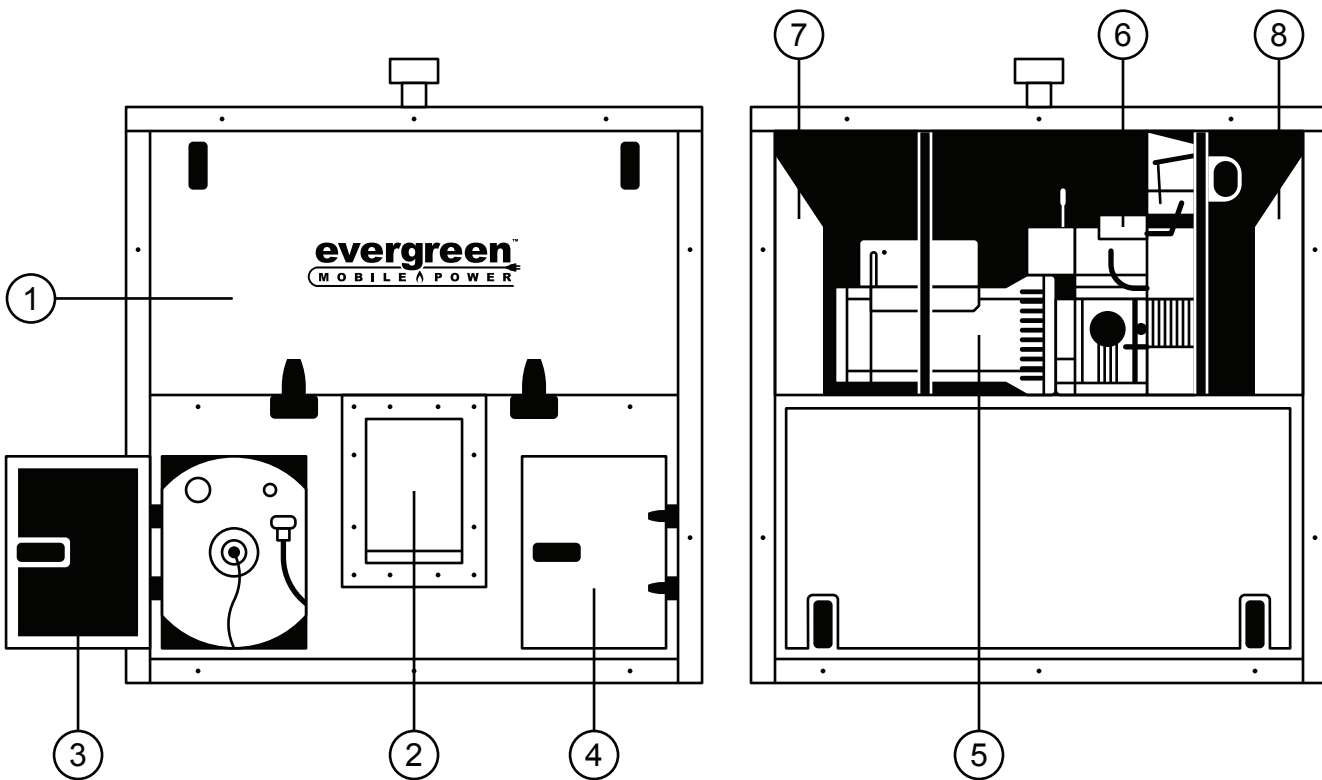

1	Engine Compartment
2	Exhaust Outlet
3	Internal Propane Fuel Tank Access
4	Internal Propane Fuel Tank Access
5	Engine
6	Valve Lash
7	Engine Bay Filter
8	Engine Bay Filter

ORIENTATION – LEFT SIDE

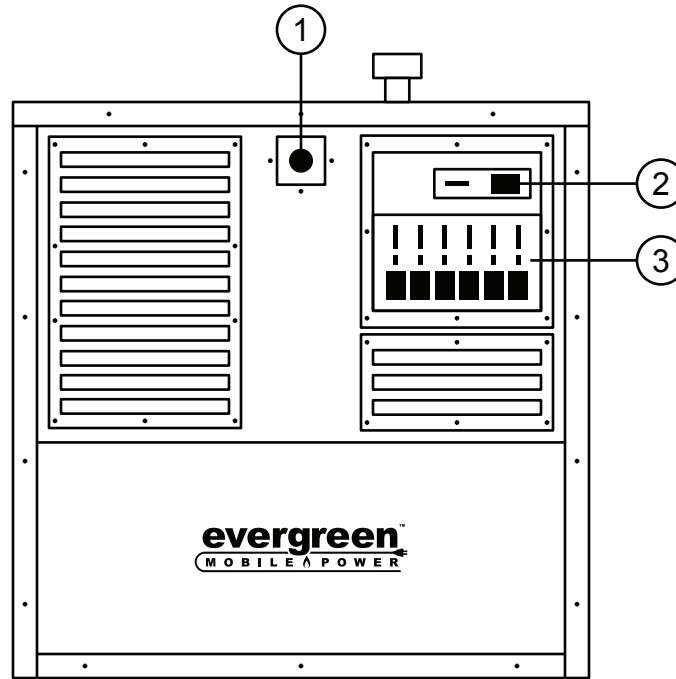

1	Emergency Shut Down Button
2	120V GFCI Outlet
3	Interchangeable Power Distribution Panel

ORIENTATION – RIGHT SIDE

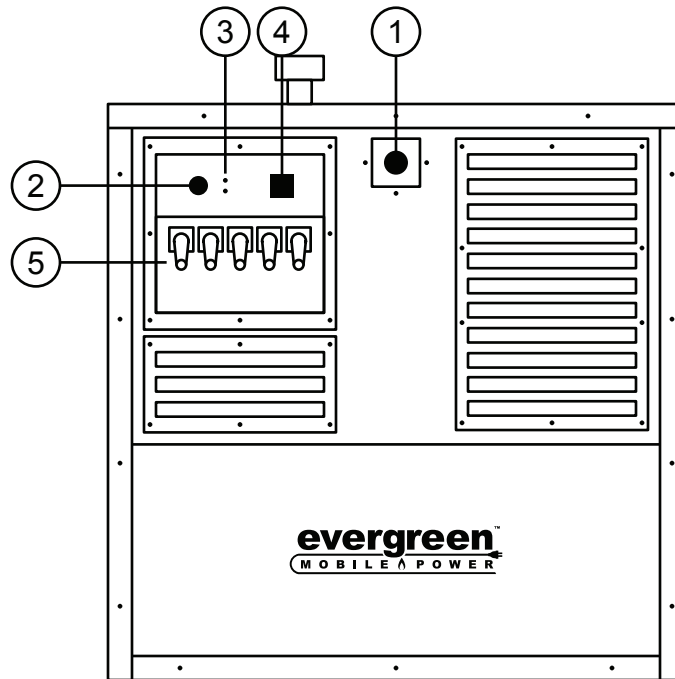

1	Emergency Shut Down Button
2	Engine Start Switch
3	Two Wire Start Terminals
4	Main Circuit Breaker
5	Interchangeable Power Distribution Panel

FUEL TANKS

There are two liquid propane tanks mounted in the lower half of the generator. Each tank has its own OPD valve (overflow protection device) that is used to refill the tank. Each tank must be refueled independently. The capacity of each tank is 32 US gallons, for a total fuel capacity of 64 US gallons. Propane vapor is released from the tanks only through the electronic solenoids and is controlled by the on board computer.

Each tank has a manual shut off located on the solenoid. It is a round wheel with a knurled edge. Turning the wheel clockwise closes the valve and counterclockwise opens it. For most operation of the generator, the manual shut off valves should remain in the open position.

In the center top of each tank is a small bleeder valve used for the refueling process to give a visual indication that the tank is full.

Lastly, each tank has a fuel level indicator. This can be read manually at the tanks, through the engine monitoring module located in the front of the generator (see page 9), or via the remote monitoring software, if your unit is equipped with this capability.

Table 3. LPG (Propane) Fuel Consumption

LOAD	25%	50%	75%	100%
Gal / hr	1.6	2.1	2.7	3.4
Btu / hr	147500	193000	244000	303000

Table 4. Natural Gas Fuel Consumption

LOAD	25%	50%	75%	100%
Cu. Ft / hr	137.6	168	196.6	245.2
Btu / hr	137600	168000	196600	245200

EXTERNAL FUEL CONNECTIONS

The generator can be connected to an external fuel source to extend run times beyond the capacity of the internal fuel tank capabilities. This is also the location of the connection of a natural gas source, if your machine is equipped to do so.

For external LPG tanks, a minimum single container must exceed 100 pounds. If your JuiceBox™ generator is made prior to Nov 2021, you will need to have a 10-psi regulator installed at the tank and a minimum supply hose of 3/8" ID. If your JuiceBox™ Generator is made from Nov 2021 on, use a 60-psi external tank regulator. If your propane supplier does not have one available, you can purchase one from Evergreen Mobile Power using part number: JBEXT-60.

All JuiceBox™ Generators use vapor when operated on propane.

For natural gas service, the natural gas supply must be 11"-14" WC and capable of supplying a minimum of 245,000 btu / hr. For natural gas usage, a 5/8" hose is recommended. The connections supplied from Energy Tree are 3/8" SAE male flare on the LPG connection and #12 JIC male flare for the natural gas connection (if equipped).

NOTE: *External fuel sources of all types should only be connected to this generator unit by licensed, qualified personnel. All applicable laws regarding fuel storage tanks and natural gas supplies should be adhered to when using them in conjunction with this generator unit.*



ENGINE BAY

Engine oil level should be checked before starting the generator and every 24 hours of operation thereafter. The engine oil system holds two and a half (2.5) quarts of oil. The proper way to check the oil is to shut the engine off for a minimum of two (2) minutes to allow the oil to return to the crankcase.

Open the engine compartment access door, located on the rear of the generator (see page 10). Locate the yellow handle of the engine oil dipstick. This is centrally located in the engine bay. Pull the dipstick completely from its tube. Using a clean, lint-free towel, wipe all oil from the dipstick. Return the dipstick into the dipstick tube, reinserting it all the way. Remove the dipstick again and read the oil level on the end of the dipstick. The oil level should be equal to the knurled (textured) section of the dipstick.

Avoid overfilling the engine, as this may cause damage to the engine. The oil fill cap is located on the front valve cover. Be sure to replace the cap after adding oil. Evergreen Mobile Power recommends Mobil Full Synthetic 10W40 engine oil for use on our products. Change the oil after the first 100 hours of use and every 250 hours of operation thereafter.

Each side of the engine bay features an engine bay air filter. These should be inspected daily and washed when dirty.



BATTERY SWITCH

The engine starting battery switch keeps the battery from draining if the JuiceBox™ is stored for long periods of time. This switch is also helpful for resetting the computers on the JuiceBox™ if that is necessary to do. The battery switch is located on the front side inside the small door in the lower half of the machine. The switch is a simple on-off switch which has spring tension when activated to the right, or on position and when turning to the left or off, the switch will snap back when activated into its off position.



FUEL SOURCE SELECTOR SWITCH

The fuel source selector switch and fine voltage adjustment knob are located in the storage area. The fuel source selector switch is used to determine where the fuel for the generator unit will come from.

Internal setting allows fuel to be used from the internal LPG tanks. External allows for fuel to be used from an external source such as an external LPG vapor tank or from a natural gas source (if equipped). The “Both” setting allows the internal LPG tanks AND an external LPG tank to be used at the same time. The generator unit cannot use propane from the internal tanks AND natural gas at the same time.

NOTE: *External fuel sources of all types should only be connected to this generator unit by licensed, qualified personnel. All applicable laws regarding fuel storage tanks and natural gas supplies should be adhered to when using them in conjunction with this generator unit.*

CONTROL MODULE

The engine / generator monitor is located below the fuel source selector switch. This monitor provides protection for the engine as well as generator functions by monitoring oil pressure, engine oil temperature, voltage, amperage, and frequency. This monitor also provides this information remotely through a cellular gateway (if equipped) and can be viewed on a computer or smartphone.

The “Stop” – “Auto” – “Start” buttons on this module are not used and should not be pressed to operate the generator unit. When the generator unit is in operation, use the up and down arrows to read performance metrics such as voltage output, amperage, frequency, engine RPM, fuel level, oil pressure, oil temperature, total hours of operation, etc.

The DSE controller is the “brain” of the Juice Box. It tells the generator to “Start” and “Stop” (when commanded), monitors the critical aspects of the engine and the generator, triggers warnings, alarms, shutdowns of the critical parameters, displays the status of various monitored parameters (Hz, Voltage, Current, kW, fuel level, battery status and charge, as well as other parameters as required).

The DSE monitors the various engine parameters through either Analogue or Digital inputs.

Analogue Inputs are typically measured inputs. The DSE puts out a low voltage on an Input channel and measures the resistance of a circuit. A fuel level sender varies the resistance as a float changes position relative to the amount of fuel in the tank. The “Oil Temperature Sender” varies resistance depending on the temperature of the oil.

Digital Inputs are typically switch contacts. The DSE puts out a low voltage, current limited signal to a switch. The switch will connect to ground when the contacts are closed. When the Input signal connects to ground (closed contacts) the voltage on the channel will go “Low”. When the switch contacts are “open” the voltage signal will go “High”. The DSE “sees” the change and responds as configured for that input. For example, when oil pressure fails, and the switch is a normally open contact, the panel will see an open contact as a loss of oil pressure and will alarm and shut the engine down. Digital inputs can be configured for normally closed or normally open contacts, as required.

The DSE also monitors and makes calculations for the Generator power.

Voltage inputs are fused inputs from the line terminals of the generator. The fuses are 2A fast acting fuses, in case of a fault in the DSE or monitoring circuits.

Current inputs are provided by current transformers for each line supply of the generator. The CTs in the Juice Box are 150A, with a 5A secondary. This provides the DSE with lower proportional current signals for each load line. The DSE will display the L-N, L-L, and current of each line as required.

The DSE will calculate and display the kW, and other measured power parameters as necessary.

CONTROL MODULE

The DSE will start and stop the machine as configured. To do so it uses Digital Output Channels. These channels are 12Vdc outputs, limited to 10 A per channel. So relays are used to connect fused power to the “Run” and “Crank” circuits. Relay 1 is for the “Run” circuit, and Relay 2, is for the “Crank” circuit. This fused power, for “Run” and “Crank” is routed through the E-Stop circuit.

There are two external E-Stop buttons. One on either side of the Juice Box, centered about 6 inches below the top, in recessed cavities. The buttons are RED and in operation are in the out position. To engage the E-Stop and shut down the machine, or keep it from starting, simply push either E-Stop button. If powered the control will display the alarm, “Emergency Stop”. The unit will neither crank, nor start with either E-Stop depressed. To reset the E-Stop simply twist and pull the RED E-Stop button. It will pop out to the “Run” position.

The E-Stop circuit consists of two power circuits and a signal circuit.

The first circuit is the “Run” circuit. Power from Fuse 1 connects from the Left Control Cabinet (LCC) fuse block, through the 40 Pin Deutsch Connector, to a switch in the left E-Stop, then crosses over to the right E-Stop switch, then back to the LCC box and Relay 1, the B1 terminal of the “Relay” block. When Relay 1 is energized this fused power is sent through the relay contacts to the control terminal strip on Wire 4A. This provides fused 12Vdc to each component of the “Run” circuit; the fuel solenoids on either the Internal Fuel Tanks, or the External Fuel source, or both; also power to the Upper and Lower Fuel Run Solenoids.

The second E-Stop circuit is the “Crank” circuit. Power from Fuse 2 connects from the LCC fuse block, to the left E-Stop, then crosses to the right E-Stop, then goes back to the LCC to R2, Terminal B3 of the “Relay” block. When Relay 2 is energized by the DSE controller, Relay 2 is energized and the power from F2 is sent to the Starter Solenoid on the Engine.

The third E-Stop circuit is the E-Signal circuit. This switch affects the Digital input of the DSE. When the E-Stop switch “opens” the ground connection from the E-Stops is opened, the voltage signal from the DSE input goes “HIGH” and the control “sees” that the E-Stop is active. The DSE will not attempt to crank or start as long as the E-Stop input is “Active”.

The DSE has an internal “Safety On” timer when the unit first starts. When the crank cycle ends, the engine is running and the timer is counting down. The timer is set for 10 seconds typically. This allows oil pressure to stabilize, as well as voltage and frequency. The DSE display will show “Safety Delay” while the timer is running.

Engine speed and power - generator frequency and kW, are controlled by the engine governor controller and actuator. The governor controller “sees” the engine RPM through a Magnetic Pickup (MPU) mounted at the engine flywheel. The engine speed is governed to maintain 3600 RPM (60 Hz using a 2-pole alternator rotor). As power demand increase the engine would slow down, so the governor responds by increasing fuel to keep the frequency at 60Hz.

CONTROL MODULE

Generator voltage is maintained constant by the Automatic Voltage Regulator (AVR). When load is applied and the voltage decreases, the AVR increases excitation voltage to the rotor to keep the output voltage at the proper value. When an inductive load is added only the AVR responds to increase the current output of the alternator while maintaining the correct voltage.



ELECTRICAL ENCLOSURE

The electrical enclosure on the right side of the generator unit houses the engine start switch and master circuit breaker. The master circuit breaker controls all the AC electrical output for the generator unit. Both distribution panels, as well as the courtesy outlet, will not provide any electrical current if the master circuit breaker is off.

Individual breakers on the removable panels themselves only provide protection to the receptacle on that panel. Cabling to the panel can be routed under the electrical panel door. The door should be closed once the electrical cabling has been connected. This keeps water away from the receptacles and circuit breakers.

POWER DISTRIBUTION PANELS

The generator unit features two removable and interchangeable electrical distribution panels. Either panel can house several different electrical configurations available from Energy Tree. Consult your Energy Tree rep for a list of available panels.

Every panel is held in place with four (4) retainer screws. Once the retainer screws are removed, the panel can be removed from the generator unit and replaced with another panel.

NOTE: *Never remove an electrical distribution panel from the generator with the engine running. It is safest to shut the engine off to perform the panel change.*

The connectors behind the removable distribution panel simply snap together. They are color coded to ensure correct polarity.

Remove a panel: remove the four (4) retaining bolts, gently slide the panel forward, away from the generator unit, reach behind the panel and disconnect the connectors, then swing the panel out of the electrical enclosure.

Install a panel: swing the panel into the enclosure, reach behind the panel, and make the electrical connections. Using a zip tie to hold the two halves of the connectors together is sometimes helpful with our five (5) wire camlock panels, due to the thickness of the wire. When putting the wires from the connectors back into the enclosure, do not allow them to touch an area that can cause an abrasion on the wire. Lastly, reinstall the four (4) retainer screws, then verify the electrical outputs with a multimeter.



POWER DISTRIBUTION PANELS

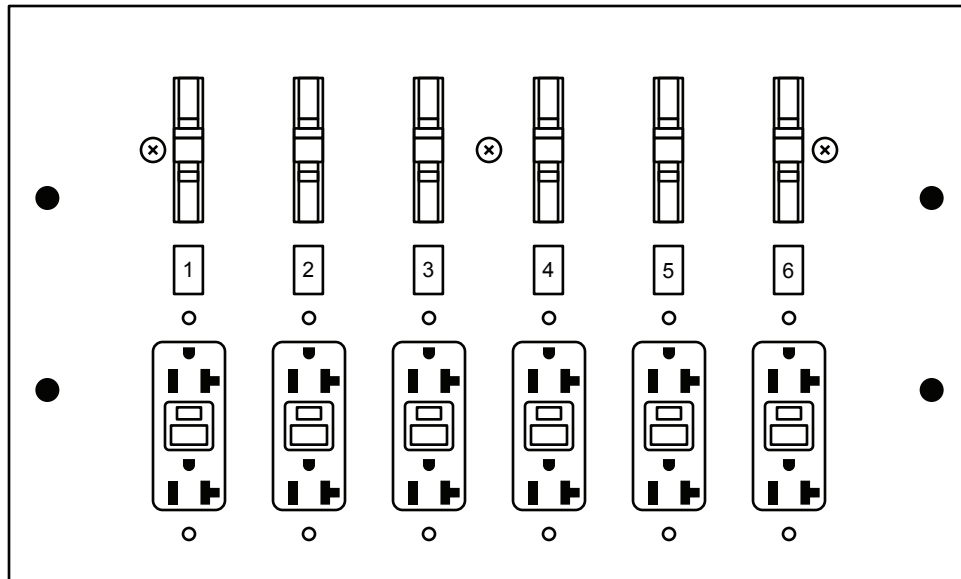

GFCI-20AMP

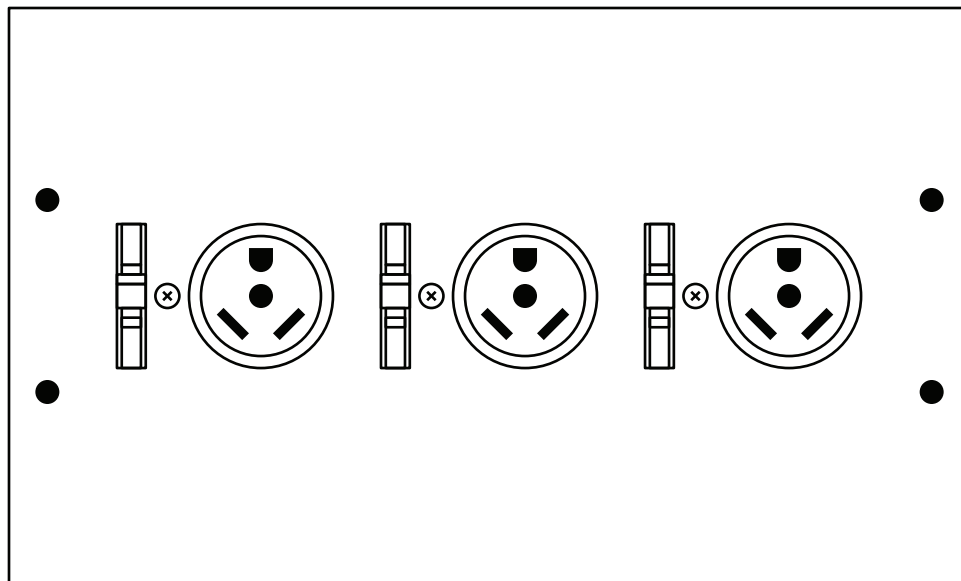

TT30

POWER DISTRIBUTION PANELS

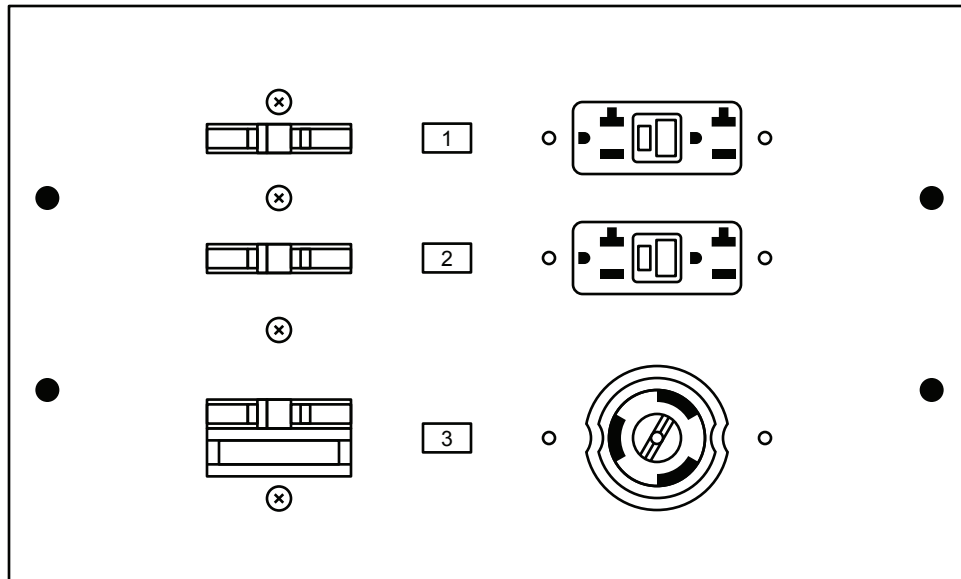

CS50-GFCI

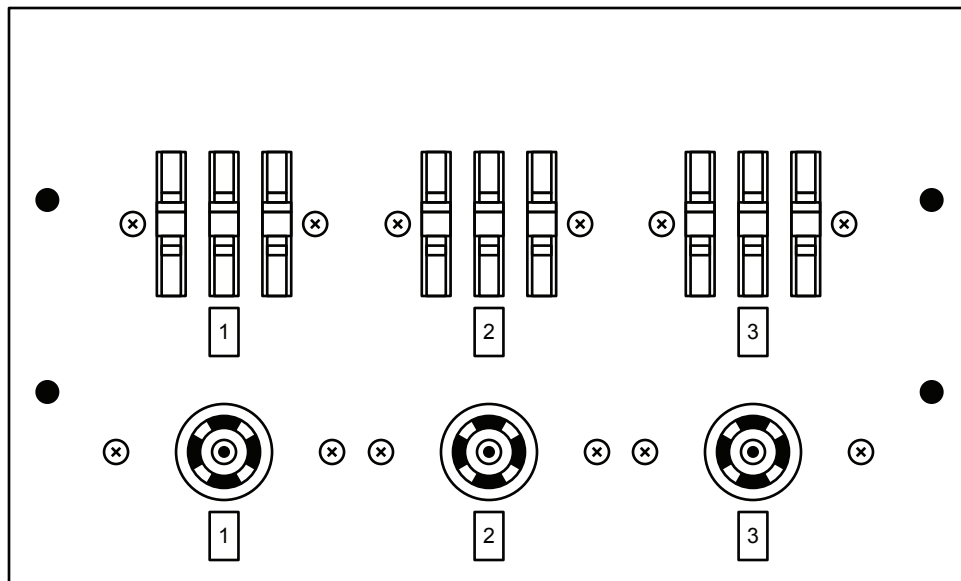

L21-20

POWER DISTRIBUTION PANELS

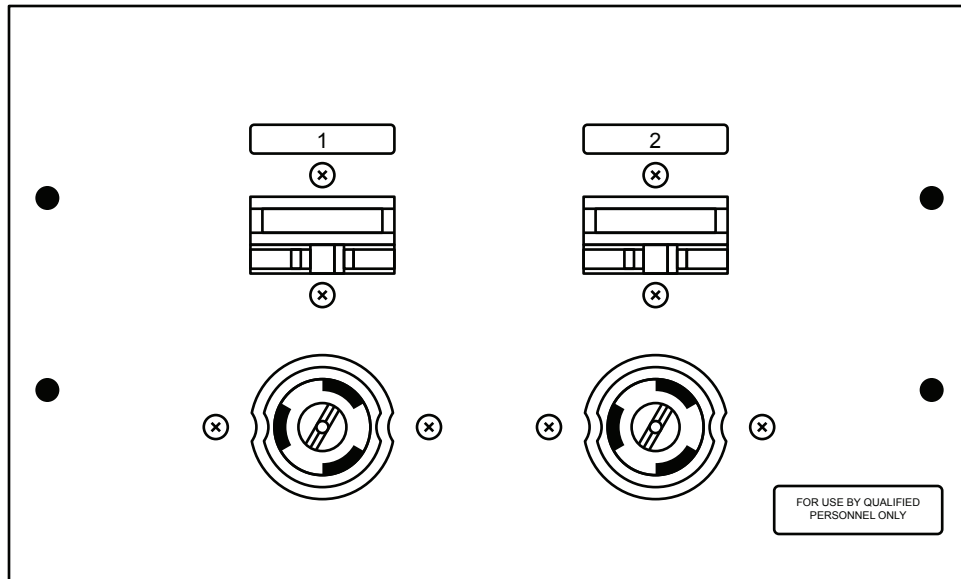

CS50

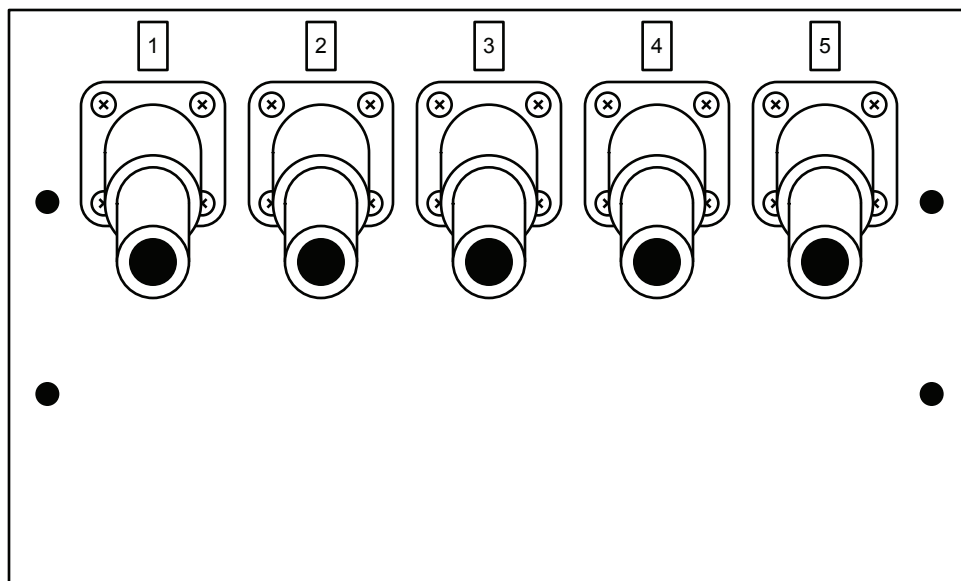

CAMLOCK

POWER DISTRIBUTION PANELS

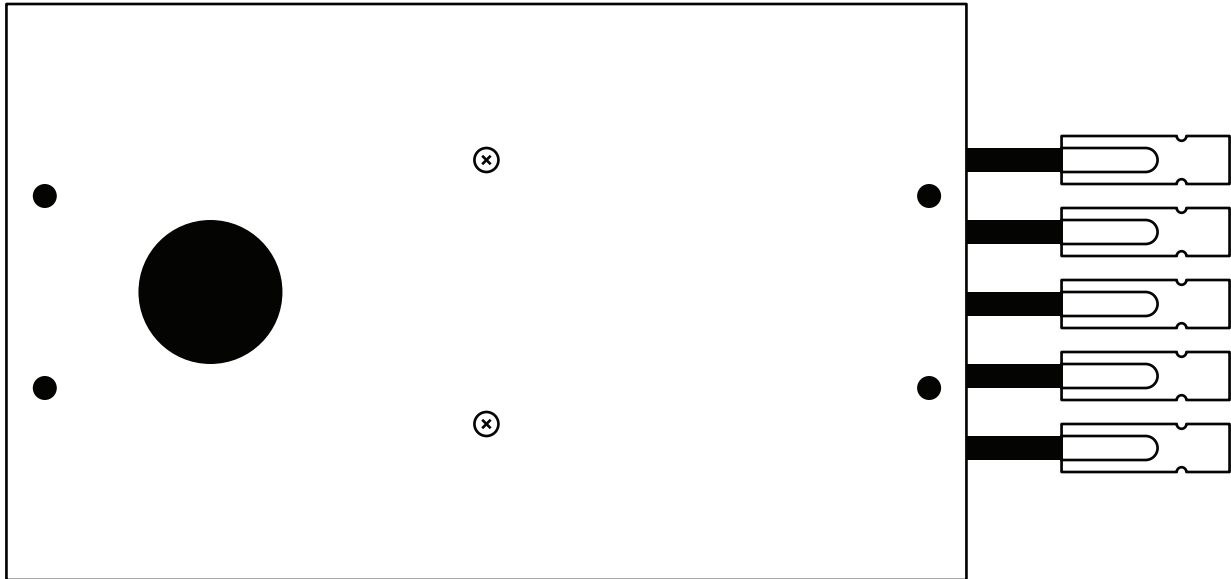

HARDWIRE

ELECTRICAL GROUNDING

An electrical connection point can be found on the front of the generator unit. From here the generator unit should be connected to an earth ground.





NOTE: *Connecting a ground to the generator unit is the only way to ensure safe operation of this equipment.*

Grounding of this equipment should be performed by a licensed electrician and done to all applicable electrical codes for the jurisdiction in which the generator unit is being used. A mechanical lug is provided on the machine for connecting your grounding lead. This generator has a bonded neutral and ground system.

FAULT CODES





If your generator isn't functioning properly, the control module located on board (see page 9) can provide some codes that may indicate what the problem is. The following is a basic troubleshooting guide. Repairs to the generator should only be performed by qualified and trained personnel. If you have any questions regarding a repair or troubleshooting, please call Energy Tree technical support at 844-KILOWATT (844-545-6928).

Table 5.1 Fault Codes

CODE	FAULT NAME	POSSIBLE CAUSE / SOLUTION
	Failed To Start	Generator did not crank the engine and did not start: verify correct battery voltage (12V DC or higher) – check battery cable connections at the battery and clean – verify battery connections to starter and chassis are clean.
	Low Oil Pressure	Engine has lost oil pressure: check engine oil level – verify oil pressure sensor wire is connected – verify engine is producing between 35-40 PSI at 3600 RPM with a manual gauge – replace sending unit if correct oil pressure exists – repair engine oil pump if proper oil pressure does not exist.
	High Oil Temperature	Engine oil temperature has exceeded the allowable amount: verify engine oil is at proper level – clean air filters on air inlets of enclosure – clean air baffles around cylinders – verify air inlets to engine bay are free of debris – check for proper oil pressure.
	Low AC Voltage Output	Generator is producing lower voltage than it should: adjust voltage at fine voltage adjustment knob – verify electrical load is not greater than generator is rated for – verify engine is operating at 3600 RPM – follow troubleshooting guide from Linz Electric app available on Apple App Store and Google Play Store and make repairs as directed.
	High AC Voltage Output	Generator is producing higher voltage than it should: adjust voltage at fine voltage adjustment knob – verify engine is operating at 3600 RPM – follow troubleshooting guide from Linz Electric app available on Apple App Store and Google Play Store and make repairs as directed.

FAULT CODES

Table 5.2 Fault Codes

CODE	FAULT NAME	POSSIBLE CAUSE / SOLUTION
	Low Frequency	Generator is producing lower frequency than it should which often times means the engine is turning too slow: check fuel level (this code can appear when out of fuel) – verify engine is operating at 3600 RPM – make sure the electrical load on the generator is not higher than it is rated for – verify air gap on mag pick up located inside flywheel blower housing is set correctly – check for adequate propane supply to engine – test gas pressure at final pressure regulator on right side of engine bay.
	High Frequency	Generator is producing higher frequency than it should: verify engine is operating at 3600 RPM – verify air gap on mag pick up located inside flywheel blower housing is set correctly – look for vacuum leaks on intake manifold – verify proper operation of the fuel actuator.
	Emergency Stop	An emergency stop button has been pressed – verify both buttons are pulled out by twisting the knob as indicated by the arrows on the knob.
	Auxiliary Input Fault	This generator uses a few different inputs that feed additional information to the control module. These are configured specific to the requirements given when the generator was built. If this symbol appears with a “A”, “B” or “C” please contact Energy Tree at 844-545-6928 and ask to speak to a technical representative for further instructions.

MAINTENANCE

Table 6. Maintenance Schedule

Oil level check should be performed daily					
HOURS OF OPERATION	Oil Change	Air Filter	Spark Plugs	Visual Inspection	Valve Lash (Adjust if required)
100	X			X	X
250	X			X	
500	X	X		X	X
750	X			X	
1000	X	X	X	X	X
1250	X			X	
1500	X	X		X	X
1750	X			X	
2000	X	X	X	X	X
2250	X			X	
2500	X	X		X	X
2750	X			X	
3000	X	X	X	X	X
3250	X			X	
3500	X	X		X	X

MAINTENANCE

Oil Change

Prior to performing an oil change, first disable the engine starting system by disconnecting the main battery switch (see page 15).

The engine and lubrication system hold 2.5 US quarts of oil. Energy Tree recommends **Mobil Full Synthetic 20W50 motor oil** and **oil filter #57148 from Wix Filters (or equivalent)** for this generator.

To avoid being burned by hot oil, ensure the engine has not been operational for at least one hour prior to draining the oil. Connect an oil resistant rubber or vinyl hose to the drain valve of the engine. Route the other end of the hose to a container below the height of the engine to capture the used engine oil. Turn the drain valve lever counterclockwise to open the valve, and oil will start to drain from the engine into your waste oil container. Once oil has stopped draining, close the drain valve by turning the “T” handle clockwise until it stops turning. Remove the oil filter by turning it counter clockwise and set it aside. Lubricate the gasket on the new oil filter and install by turning clockwise until hand tight. Disconnect the hose and clean away any oil from inside the engine bay.

Add engine oil through either yellow oil cap located in one of the valve covers located at the top of the engine. The cap is removed by turning counterclockwise. Add the engine oil slowly through the hole in the valve cover. Replace the oil cap.

NOTE: *Dispose of used oil, oil filters, and associated waste by following laws in your area. Used oil is a valuable resource and can be re-purposed. Please dispose of it responsibly.*

Air Filter Replacement

To remove the air filter, locate the engine air filter assembly on the right hand side of the engine bay. On the top of the housing is a large nut that holds the air filter housing to the engine. Under the housing is the air filter which also has a nut that holds a plate keeping the air filter flush with the top of the carburetor assembly. Remove both nuts by turning counterclockwise. After removing the nut from the top of the air filter, be sure to save the large plate, as it must be reinstalled with the new air filter. Clean the retaining plate and filter housing. Use **Briggs and Stratton air filter # 841239**. Reinstall the filter, retaining plate, nut, air filter housing, and housing retaining nut.

MAINTENANCE

Valve Lash Adjustment

To keep the engine operating properly, a valve lash adjustment will need to be made after the first 150 hours of usage, then again at 500. After that, it is recommended to verify the valve lash after each 1000 hours of usage.

IMPORTANT

Prior to performing the valve lash adjustment, please verify the machine fuel source has been shut off and the battery switch has been switched to **OFF**. In some cases, it may be easier to remove the roof and top engine cover to perform this adjustment. **This procedure must be performed on an old engine.**

1. Remove both spark plug wires from both spark plugs and tie back out of the way of the valve covers. There is one spark plug wire located on each side of the engine. Also using a 5/8" spark plug socket remove both spark plugs. Using a 10 mm socket remove both valve covers and set aside. The valve cover gaskets usually stay intact and if they appear to be broken, replace.
2. Remove the exterior louver / filter assembly from the left side engine bay by removing the (10) bolts that surround the louver assembly. This may also be a good time to clean the washable air filter. Once removed the rear of the alternator will be accessible.
3. Using a pick or small metal screwdriver, gently pry at an angle to remove the round plug that covers the center rear of the alternator. This will give you access to the nut and shaft that keeps the engine and armature held together.
4. Using the 13 mm nut, **ONLY** rotate the engine clockwise. Also, do not attempt this with the spark plugs installed as damage to the crankshaft may occur. The engine should spin freely.
5. As you rotate the engine clockwise, watch the rocker arms push the valves open and closed. Choose a cylinder to do first. Look for the intake valve to open then close. Keep rotating the engine slowly until the exhaust valve opens and closes. Just as the exhaust valve closes, insert a screwdriver into the spark plug hole to verify the location of the piston. Continue to rotate the engine until the piston reaches TDC (top dead center) which will be when the screwdriver no longer travels up. Once the piston has stopped its upward movement, stop rotating the engine. Using a .009 feeler gauge, check the gap between the valve stem and bottom of the rocker arm on both valves for that cylinder. There should be a slight drag on the feeler gauge but not so much that the gauge doesn't fit easily or is too sloppy.

MAINTENANCE

6. If adjustment is necessary, use an offset 13 mm boxed end wrench and a T40 Torx socket to loosen the retaining nut. Tighten or loosen the Torx socket to allow the .009 feeler gauge between the valve stem and rocker arm. Tighten the retaining nut and verify with the .009 feel gauge once again. Do this for both valves on that cylinder if necessary.
7. Follow this same procedure for the other cylinder and refer to step 5 if necessary.
8. Reinstall valve covers then spark plugs and reconnect the spark plug wires. Install the nut cover on the rear of the alternator and bolt exterior louver assembly back on the machine.



OPTIONAL EQUIPMENT

On-Highway Trailer

The JuiceBox™ generator can be used as a skid package or on a highway-capable trailer. These trailers have several unique features to make the generator a more useful machine. The trailer features four (4) leveling jacks that have drop-down feet, so leveling the generator is easy with no additional cribbing.

Each corner of the trailer features a D ring. These are especially useful for securing the trailer and generator package to a larger trailer when hauling multiple units.

While the generator can be mounted on its trailer in any position, the recommended position is with the REAR of the generator to face the FRONT of the trailer. This places the proper weight on the tongue of the trailer. When mounting the generator to the trailer, the front of the trailer has two (2) permanent C-channel brackets. These accept the fork pockets of the generator and keep the generator from sliding forward on the trailer. When properly seated, the fork pockets at the rear of the trailer should now be flush with the rear crossbeam of the trailer. This also is where the rear bolt-on C bracket secures the generator to the trailer and keeps the generator from sliding off the trailer to the rear. Each C bracket has a bolt on the bottom that pulls the bracket down, clamping the generator to the trailer. Each bracket also has a hole where a bolt, washer, lock washer, and nut secure the C bracket to the rear crossmember. When attaching the rear trailer bracket, put the bolt, washer, lock washer, and nut combination through the bracket and crossmember, securing hand-tight. Tighten the lower bolt with a ratchet wrench, then finish tightening the crossmember bolt with a ratchet wrench.

NOTE: *Always check all fasteners and lug nuts are tight prior to taking the generator on the highway.*

The trailer axle is a torsion axle, which provides a smooth ride for the generator at highway speeds. **Tires should be inflated to 50 PSI.**

The JuiceBox™ trailer features a removable tongue for space savings and/or theft deterrent. To remove the tongue, disconnect the trailer wiring disconnect located near the rear of the trailer tongue, remove the 2 bolts that secure the tongue to the trailer, and remove the tongue.

NOTE: *The trailer tongue is heavy. This procedure should be done by two people.*



OPTIONAL EQUIPMENT

Natural Gas Operation

If equipped, the generator can use natural gas as its fuel source. In this case, the fuel selector valve must be switched to “NATURAL GAS” or “NG” (if abbreviated). This valve will be located behind the upper door on the FRONT of the machine. A fuel source of at least 245000 btu @ 11-14” WC should be used. Please note that the fuel source selector switch inside the FRONT compartment should be switched to EXTERNAL (see page 9). Also, the water heater (if equipped) will not operate in this mode.

NOTE: *These connections should be made by licensed personnel in coordination with the natural gas supplier.*

After switching the fuel selector valve to NATURAL GAS, you will also need to switch the fuel orifice located in the engine bay (see page 10) to NG from LP, if this has not already been done. Follow this same procedure in reverse to start using LPG as a fuel source again.

GPS Monitoring

When equipped with the Energy Tree monitoring system, your generator can give you performance metrics such as voltage output, amperage, frequency, oil pressure, fuel level, and oil temperature. You can also view the location of your JuiceBox™. The monitoring system can even send alerts to a smartphone via text message. This system is also available as an app through the Apple App Store or the Google Play Store. Ask your Energy Tree representative about using this feature.

4-Point Lifting

Make using your JuiceBox™ generator even easier by adding our 4-point lifting system. These lifting loops give you even more ability to maneuver your generator wherever you need it.

Water Heater

One of the most unique features of the JuiceBox™ generator is its ability to heat water for use with cooking, cleaning, etc. This water heater can heat water at 1.6 gal per minute, at a temperature rise of 45°F above ambient temperature.

Prior to use, install two (2) D cell batteries in the compartment under the heater body.

NOTE: *This water heater will only operate when the engine is running and on propane as the selected fuel. If your generator is connected to natural gas, the heater is inoperable. The heater is activated by minimum water pressure of 30 psi and should not exceed 80 psi.*

(Continued on next page)

OPTIONAL EQUIPMENT

When using the heater to heat water for less than five (5) continuous minutes, the door covering the water heater compartment may remain closed. If operating the water heater for more than five (5) continuous minutes, leave the door open to ensure proper ventilation.

To use the water heater, connect a standard garden hose to the inlet port located on the front of the machine, and another garden hose to the outlet.

NOTE: *The hot water from this heater can lead to injury. Take necessary precautions when using hot water from this system. When not in use, close the propane gas supply valve located below the heater.*

WIRING DIAGRAMS

Upper Harness Overview (Schematic Key On Following Pages)

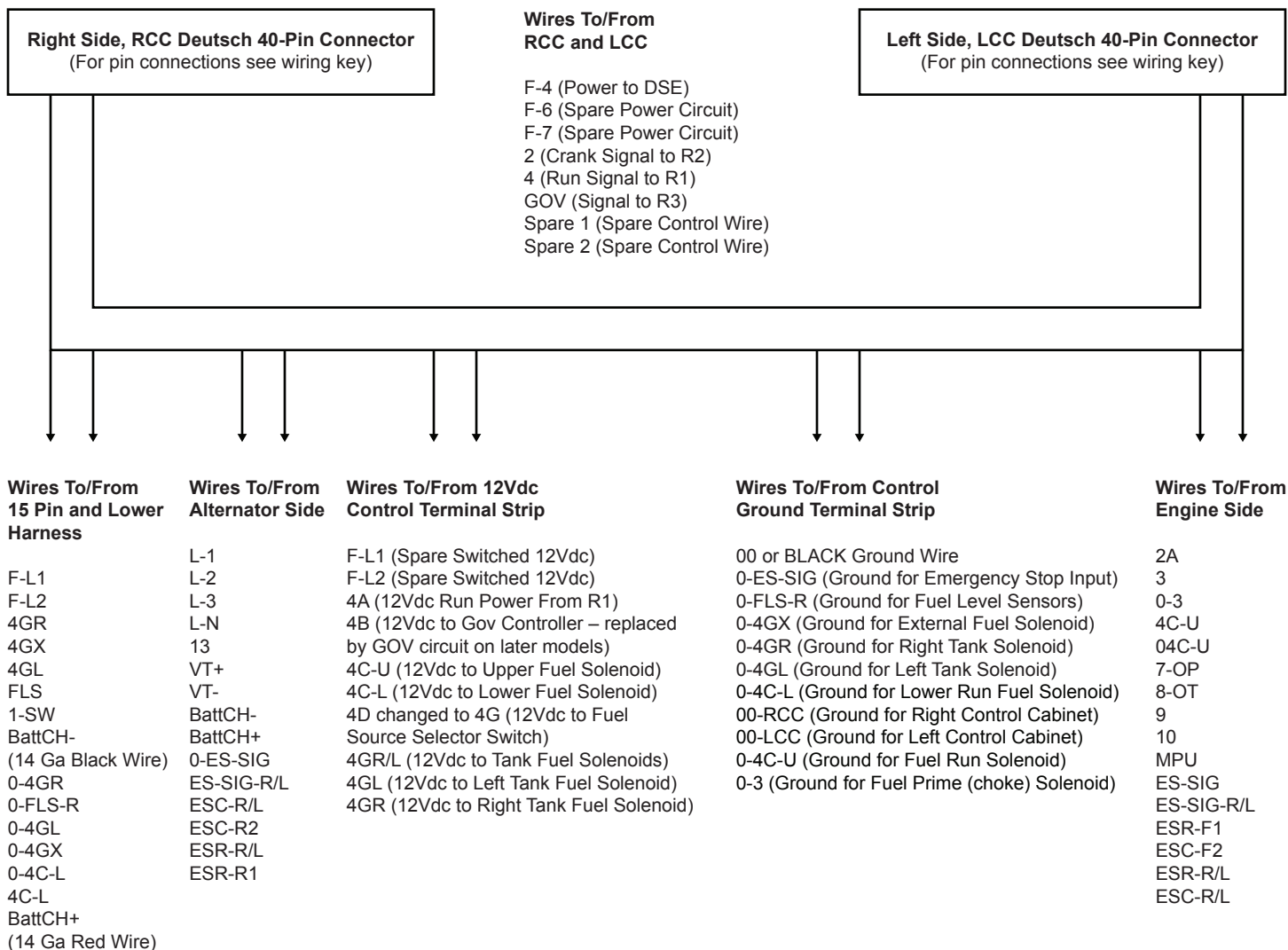

WIRING DIAGRAMS

Table 7. Main Ground Terminal Strip

WIRE NUMBER	TSA #	Function / Purpose / Operation
0-ES-SIG	1A-(T)	Ground for DSE DI for E-Stop Signal
00	1A-(B)	Main Battery Ground (14 Ga wire) from Battery Negative
0-3	2A	Ground for Solenoid, Choke (Fuel Prime)
0-FLS	3A-(T)	Ground for Fuel Level Sensor
0-4GX	3A-(B)	External Fuel Tank Solenoid Ground
0-4C-U	4A-(T)	Ground for Run Fuel Solenoid (Upper)
0-4GR	4A-(B)	Right Fuel Tank Solenoid Ground
	5A-(T)	
0-4GL	5A-(B)	Left Fuel Tank Solenoid Ground
00-L	6A-(T)	Control Ground to Left Control Cabinet
	6A-(B)	
00-R	7A-(T)	Control Ground to Right Control Cabinet
	7A-(B)	
0-4C-L	8A-(T)	Ground for Run Fuel Solenoid (Lower)
	8A-(B)	
	9A-(T)	
	9A-(B)	
	10A-(T)	
	10A-(B)	

WIRING DIAGRAMS

Table 8. Main Terminal Strip (12Vdc Control)

WIRE NUMBER	TS #	Function / Purpose / Operation
4A	1-(T)	Power for Run Circuit – From R-1. (15 A FUSED, F1)
	1-(B)	
4B	2-(T)	Run Power to Governor Controller (older units) – Governor Controller is now powered by Fuse 5
	2-(B)	
4C-U	3-(T)	Run Power to Upper Fuel Solenoid (below Fuel Regulator)
	3-(B)	
4C-L	4-(T)	Run Power to Lower Fuel Solenoid (in Lower Section)
4G	4-(B)	Run Power to Three Position Fuel Source Selector Switch
F-L1	5-(T)	Switched, Fused (15A) 12Vdc Power from Lower Section
	5-(B)	
	6-(T)	
F-L2	6-(B)	Switched, Fused (15A) 12Vdc Power from Lower Section
	7-(T)	
	7-(B)	
	8-(T)	
4G-L	8-(B)	
	9-(T)	Run Power from Fuel Source Selector Switch to Left Internal Fuel Tank Solenoid
	9-(B)	
4G-R	10-(T)	Run Power from Fuel Source Selector Switch to Right Internal Fuel Tank Solenoid
4G-R/L	10-(B)	Run Power from Fuel Tank Solenoid from Fuel Source Selector Switch

WIRING DIAGRAMS

Table 9. Right Control Cabinet (Alternator & Control Panel Side) 40 Pin Deutsch Connector

WIRE NUMBER	PIN #	Function / Purpose / Operation
00-R	1	Control Ground from TSA
3	2	Fuel Prime Signal to Fuel Prime Solenoid (Choke)
4	3	Run Signal to R-1 – Powers up all “4” wires
2	4	Crank Signal to R-2
13	5	Battery Charger Output Voltage
NA	6	
7-OP	7	Oil Pressure Switch Signal
8-OT	8	Oil Temperature Sensor Signal
FLS	9	Fuel Level Sensor Signal
GOV	10	Output to Control Relay 3 – Spare Relay
ES-SIG	11	Emergency Stop Signal
4GX	12	External Fuel Source Selector Solenoid Power
F4	13	Fuse Power (F4, 15A) to DSE
4G	14	Power from Run Circuit through Fuel Source Selector Switch to appropriate Solenoids
4G-R/L	15	Power from Fuel Source Selector Switch to Internal Tank Solenoid
L-1	16	Generator Voltage Sensing, Line 1 (Phase A, U, or V - BLACK)
L-2	17	Generator Voltage Sensing, Line 2 (Phase B, V - RED)
L-3	18	Generator Voltage Sensing, Line 3 (Phase C, W - BLUE)
L-N	19	Generator Voltage Sensing, Line NEUTRAL - WHITE
F6	21	Fused Power for other option
F7	22	Fused Power for other option
Spare 1	23	Fused Power for other option
Spare 2	24	Fused Power for other option
VT+	31	Voltage Adjust Potentiometer, to ACR in Alternator Connection Box
VT-	32	Voltage Adjust Potentiometer, to ACR in Alternator Connection Box
Not Used	33 - 40	

WIRING DIAGRAMS

Table 10. Left Control Cabinet (Engine & Fuse/Relay Panel Side) 40 Pin Deutsch Connector

WIRE NUMBER	PIN #	Function / Purpose / Operation
ESC-F2	1	From F1 to Left E-Stop, through Right E-Stop, then back to R2 for Crank
4A	2	Power from R1 to Run Circuits (TS 1-4)
2	3	Crank Signal from DSE to R2, to Crank
ESR-R1	4	Power from E-Stops (F2) to R1 for Run Circuits Power
2A	5	Crank Command from R2 to Starter Solenoid to Crank
ESR-F1	6	From F2 to Left E-Stop, through Right E-Stop, then back to R1 for Run Circuit
ESC-R2	7	Power from E-Stops (F1) to R2 for Crank Power
4	8	Signal from DSE to R1 to Energize Run Relay (R1)
1	9	12Vdc Switched Battery to Fuse/Relay Power Terminal
GOV	10	
9	11	Governor Power to Actuator
10	12	Governor Power to Actuator
F4	13	Fused 12Vdc from F4 for DSE
00-L	14	Ground for Left Control Cabinet
Not Used	15 - 20	
F6	21	Fused Power to RCC for other options – In second iteration of harness
F7	22	Fused Power to RCC for other options – In second iteration of harness
Spare 1	23	Spare Control Wire to RCC for other options – In second iteration of harness
Spare 2	24	Spare Control Wirer to RCC for other options – In second iteration of harness
Not Used	25 - 40	

WIRING DIAGRAMS

Table 11. Other Connections (Engine, Alternator, Etc.)

WIRE NUMBER / SOURCE	Function / Purpose / Operation
2A (LCC)	Power to Crank Solenoid from R2
3 (RCC)	Power to Fuel Prime Solenoid
4A (LCC)	Run Power from R1 to Run Circuits (TS 1-4)
7-OP (RCC)	Oil Pressure Switch
8-OT (RCC)	Oil Temperature Sender
9 (LCC)	Governor Actuator Signal
10 (LCC)	Governor Actuator Signal
13 (RCC)	Battery Charger Output Voltage
VT+ (RCC)	AVR in Alternator Connection Box (M8)
VT- (RCC)	AVR in Alternator Connection Box (M6)

Table 12. 15 Pin Connector From Upper To Lower Harness

WIRE NUMBER	PIN #	Function / Purpose / Operation
F-L1	1	15A Fuse Providing Un-Switched 12Vdc to the Terminal Strip – For other use
F-L2	2	15A Fuse Providing Un-Switched 12Vdc to the Terminal Strip – For other use
4GR	3	Power to Fuel Solenoid on Right Fuel Tank
4GX	4	Power to Fuel Solenoid for External Tank Connection
4GL	5	Power to Fuel Solenoid on Left Fuel Tanks
FLS-L	6	Upper Harness is Wire FLS – Lower Harness labeled FLS-L, goes to Left Fuel Level Sensor
1-SW	7	Switched 12Vdc from the Battery Disconnect Switch
Batt- CH	8	Battery Ground Wire – 14 Ga BLACK Wire – From Battery Charger
0-4GR	9	Ground for Fuel Solenoid on Right Fuel Tank
0-FLS-R	10	Upper Harness is Wire 0-FLS – Lower Harness labeled 0-FLS-R, goes to Right Fuel Level Sensor
0-4GL	11	Ground for Fuel Solenoid on Left Fuel Tank
0-4GX	12	Ground for External Fuel Source Solenoid
0-4C-L	13	Ground for Lower RUN Fuel Solenoid
4C-L	14	Power to Lower RUN Fuel Solenoid
Batt+ CH	15	Wire from Battery Charger Output to Battery – 14 Ga RED Wire – From Battery Charger
Fuel Level Sensor Circuit		The Fuel Sensing Signal from the DSE Panel is an Analog (B), Low Voltage – The DSE reads the change in resistance in Fuel Level Sensors – Wired in Series: FLS, FLS-L, FLS-L/R (connects the two sensors), and 0-FLS-R (ground reference)

WIRING DIAGRAMS

Right Control Cabinet (RCC)

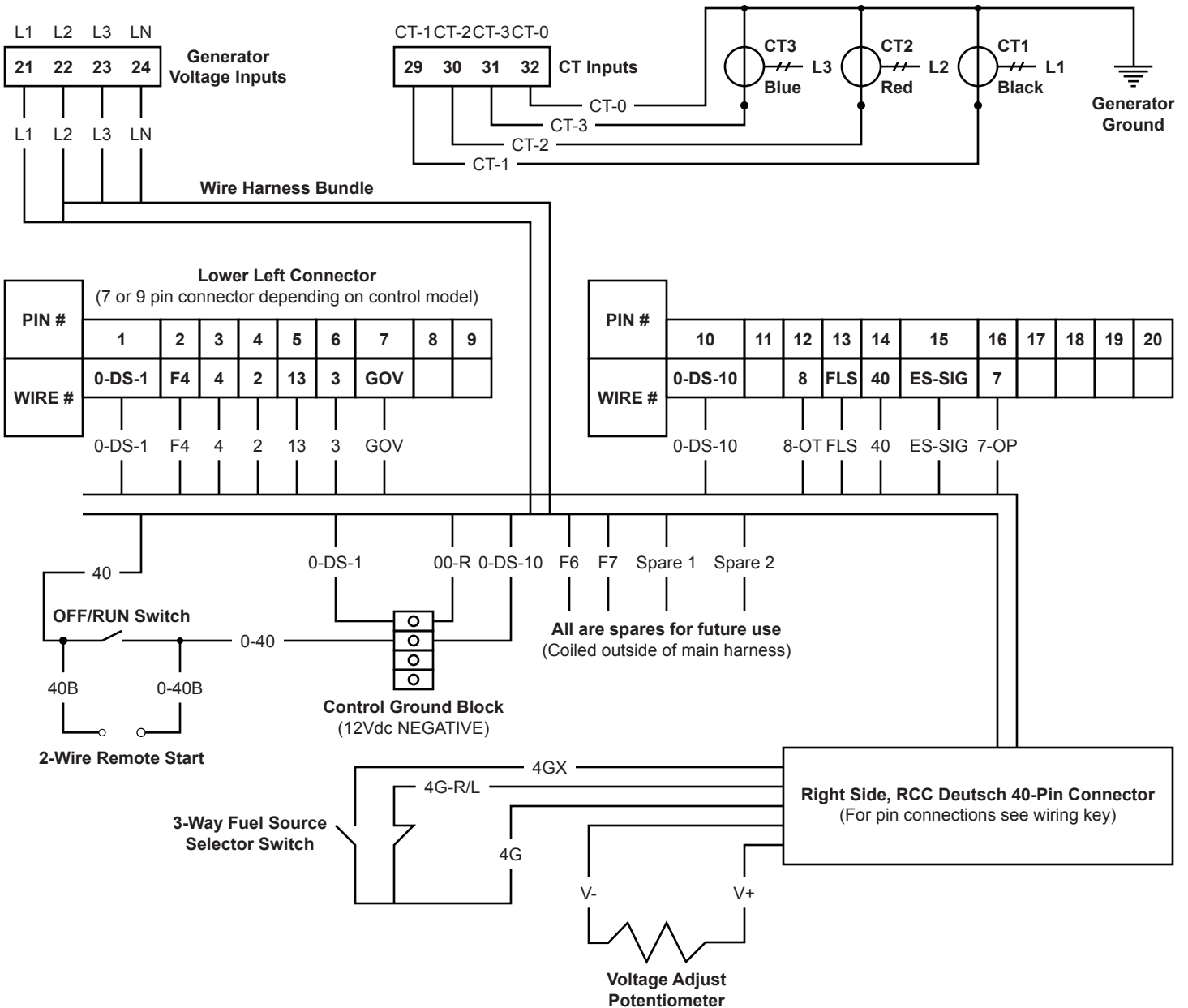

WIRING DIAGRAMS

Table 13.1 Right Control Cabinet (RCC) Schematic Key

WIRE NUMBER	DSE PIN #	40 PIN Deutsch #	Function / Purpose / Operation
00-R	N/A	1	Battery Control Ground for DC Circuits – Connects to Control Ground Terminal Strip (yellow/green)
0-DS-1	1	N/A	Battery Control Ground for DSE Power – Connects to Control Ground Terminal Strip
F4	2	13	Switched, Fused (F4, 15A) Battery Positive Voltage – From LCC Fuse Panel
4	3	3	Digital Output A, 12Vdc to Relay 1 (Run Relay) – Signal to change the state of Relay (R-1)
2	4	4	Digital Output B, 12Vdc to Relay 2 (Crank Relay) – Signal to change the state of Relay (R-2)
13	5	5	Battery Charge Voltage from Output of AC Battery Charger
3	6	2	Digital Output C, 12Vdc to Fuel Prime Solenoid (Choke) - Straight to Prime Solenoid
GOV	7	10	Digital Output D, 12Vdc to Governor Power Relay
N/A	8	N/A	
N/A	9	N/A	
0-DS-10	10	N/A	Control Ground for Analog Channels – Must connect to Engine Ground
N/A	11	N/A	
8-OT	12	8	Analog Input Channel B, Coolant Temp (Oil) – Standard VDO – 0-120 ohm resistive element
FLS	13	9	Analog Input Channel C, Fuel Level Sensor – Wired in series to Ground – 0-180 ohms
40	14	N/A	Digital Input Channel A, “Remote Start On Load” – From OFF/RUN Switch
ES-SIG	15	11	Digital Input Channel B, Emergency Stop – Wired in series through E-Stops to Control Ground
7-OP	16	7	Digital Input Channel C, “Oil Pressure” Switch – Single pole (closed) or double pole (open)
N/A	17 - 20	N/A	
L-1	21	16	L-1 Sensing Voltage Input – Fused 2A, Fast Acting
L-2	22	17	L-2 Sensing Voltage Input – Fused 2A, Fast Acting
L-3	23	18	L-3 Sensing Voltage Input – Fused 2A, Fast Acting
L-N	24	19	L-N Sensing Voltage Input – Not Fused
N/A	25 - 28	N/A	For Mains Voltage Sensing (if equipped) – Not used for standby
CT-1	29	N/A	Current Sensing Input, L-1
CT-2	30	N/A	Current Sensing Input, L-2
CT-3	31	N/A	Current Sensing Input, L-3
CTGrnd/CT-0	32	N/A	Current Sensing Input, Reference, Generator Ground – One must be connected to Ground
VT+	N/A	31	Voltage Adjust Potentiometer Lead
VT-	N/A	32	Voltage Adjust Potentiometer Lead
4GX	N/A	12	Run Power from Fuel Source Selector Switch to External Fuel Tank Solenoid
4G	N/A	14	Run Power to Fuel Source Selector Switch (3-Way Switch)

WIRING DIAGRAMS

Table 13.2 Right Control Cabinet (RCC) Schematic Key

WIRE NUMBER	DSE PIN #	40 PIN Deutsch #	Function / Purpose / Operation
4G-R/L	N/A	15	Run Power for Fuel Source Selector Switch to Internal Fuel Tanks
F6	N/A	21	Fused Power for other option – Run through harness to same pin on LCC Deutsch Connector
F7	N/A	22	Fused Power for other option – Run through harness to same pin on LCC Deutsch Connector
Spare 1	N/A	23	Control Wire for other option – Run through harness to same pin on LCC Deutsch Connector
Spare 2	N/A	24	Control Wire for other option – Run through harness to same pin on LCC Deutsch Connector

WIRING DIAGRAMS

Left Control Cabinet (LCC)

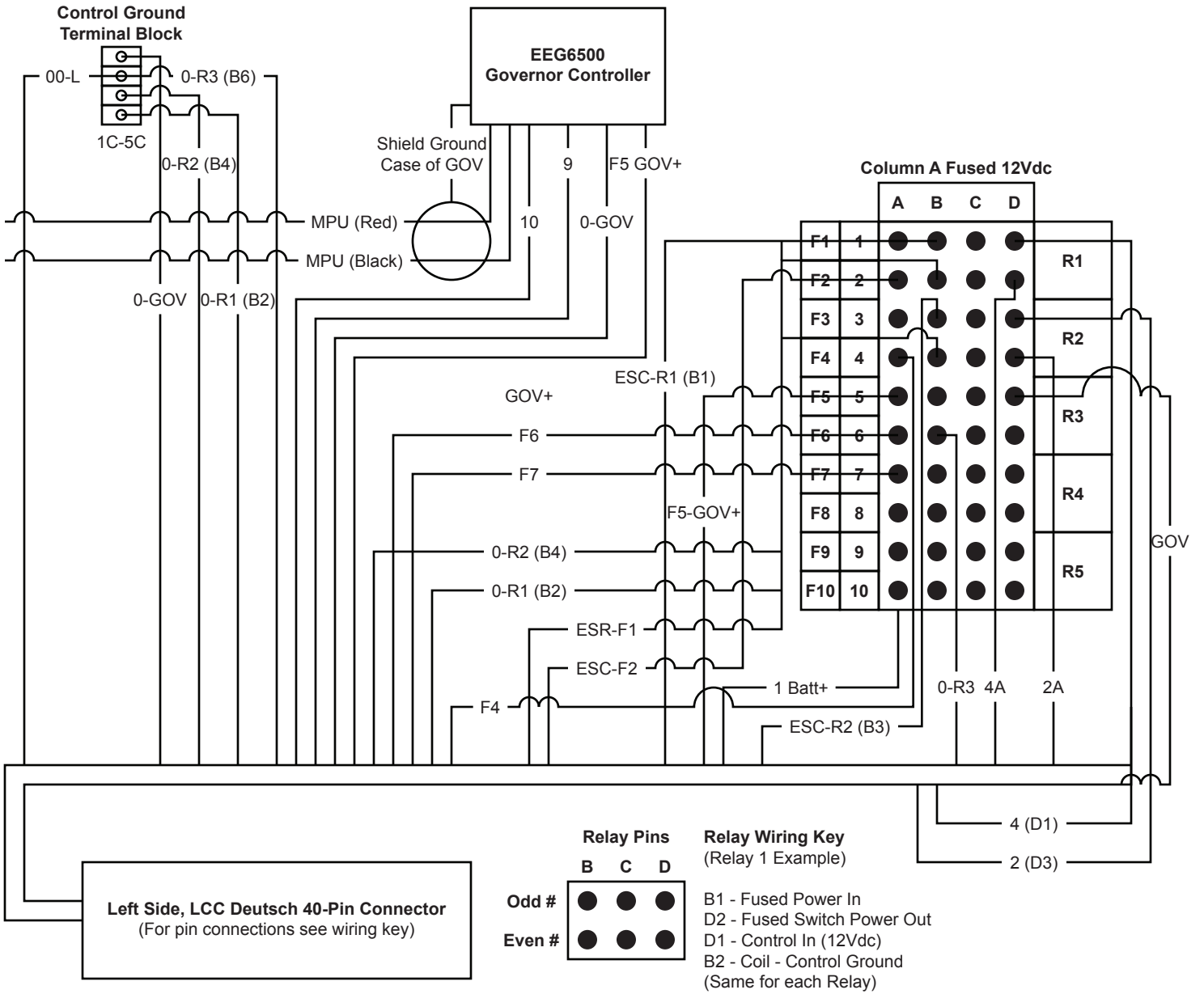

WIRING DIAGRAMS

Table 14. Left Control Cabinet (LCC) Schematic Key

WIRE NUMBER	40 PIN Deutsch #	Function / Purpose / Operation
ESC-F2	1	Fused Power from E-Stops to R2 (D3) – Wire comes from F2
4A	2	Fused Power from Run Relay, R1 (D4) to Run Circuit at Main Terminal Strip, 1-4
2	3	Signal from DSE DO-2, to Crank Relay
ESR-R1	4	Fused Power through E-Stop Circuit to Relay 1 (B1)
2A	5	Fused Switched Power from Relay 2 (D4) to Crank Solenoid
ESR-F1	6	Fused Power from F2 (A2) through E-Stop Circuit to R1 (B1) – Wire comes from F1
ESR-R2	7	Fused Power from F1 (A1) through E-Stop Circuit to R2 (B3)
4	8	Control Signal from DSE DO-1, to R1 (D1)
1	9	12Vdc Switched Batt+ to feed Fuse Strip on Fuse/Relay block
GOV	10	Spare Control for Relay 3
9	11	Governor Controller Output to Actuator
10	12	Governor Controller Output to Actuator
F4	13	Switched Fused 12Vdc from F4 (A4) to RCC and DSE pin 2, for DSE Power
00-L	14	Control Ground from Main Ground Terminal Strip 6A – Battery Ground for Control Circuits
MPU	N/A	MPU 2 Wire shielded twisted pair – Run separately to MPU on Engine
F5-GOV+	N/A	Fused Battery Power from F5 to Batt+ Terminal of Governor Controller
0-GOV-	N/A	Batt Ground from Terminal Strip Ground to Governor Controller – Batt- Terminal
F6	21	Fused Power to RCC for other options – In second iteration of harness
F7	22	Fused Power to RCC for other options – In second iteration of harness
Spare 1	23	Spare Control Wire to RCC for other options – In second iteration of harness
Spare 2	24	Spare Control Wire to RCC for other options – In second iteration of harness

WIRING DIAGRAMS

Fuse/Relay Panel

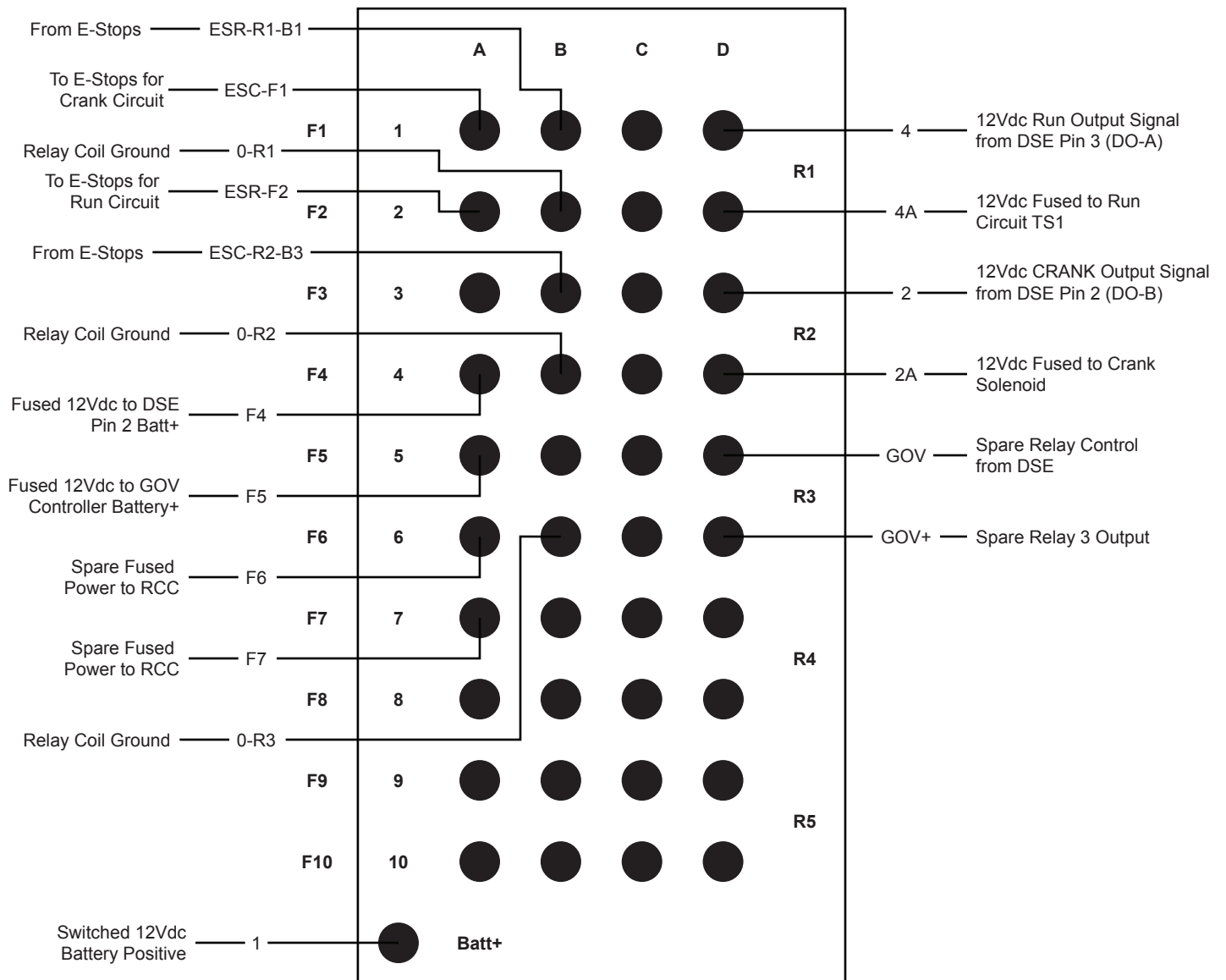

E-Stop Circuit

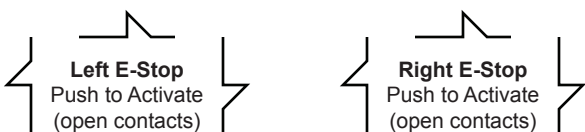

PRODUCT WARRANTY

Energy Tree, LLC warrants this product and its parts against defects in materials or workmanship for one year or 3000 hours from the original ship date. During this period, Energy Tree, LLC will repair or replace defective parts with new or reconditioned parts at Energy Tree, LLC's option, without charge to you.

Shipping fees incurred from returns for under-warranty service in the first thirty (30) days will be paid by Energy Tree, LLC. All shipping fees both to and from an Energy Tree, LLC authorized service center following this 30-day period must be paid by the owner. All returns, both during and following the 30-day period, must be effected via the Procedures for Obtaining Warranty Service described below.

All original parts (installed by Energy Tree, LLC at the original build) replaced by Energy Tree, LLC or its authorized service center, become the property of Energy Tree, LLC. Any aftermarket additions or modifications will not be warranted. The product owner is responsible for the payment, at current rates, for any service or repair outside the scope of this limited warranty.

Energy Tree, LLC makes no other warranty, either express or implied, including but not limited to implied warranties of merchantability, fitness for a particular purpose, or conformity to any representation or description, with respect to this product other than as set forth below. Energy Tree, LLC makes no warranty or representation, either express or implied, with respect to any other manufacturer's product or documentation, its quality, performance, merchantability, fitness for a particular purpose, or conformity to any representation or description.

Except as provided below, Energy Tree, LLC is not liable for any loss, cost, expense, inconvenience or damage that may result from use or inability to use the product. Under no circumstances shall Energy Tree, LLC be liable for any loss, cost, expense, inconvenience or damage exceeding the purchase price of the product.

The warranty and remedies set forth below are exclusive and in lieu of all others, oral or written, expressed or implied. No reseller, agent or employee is authorized to make any modification, extension or addition to this warranty.

(Continued on next page)

PRODUCT WARRANTY

Warranty Conditions

The Limited Warranty on the previous page is subject to the following conditions:

1. This warranty extends only to products distributed and/or sold by Energy Tree, LLC and or its authorized service centers. It is effective only if the products are purchased and operated in the USA (within the USA including US 48 States, Alaska and Hawaii).
2. This warranty covers only normal use of the product. Energy Tree, LLC shall not be liable under this warranty if any damage or defect results from (i) misuse, abuse, neglect, improper shipping or installation; (ii) disasters such as fire, flood, lightning or used improperly for electrical configurations not designed by Energy Tree, LLC ; or (iii) service or alteration by anyone other than an authorized Energy Tree, LLC representative; (iv) damages incurred through irresponsible use, including modifications, or other non-recommended practices.
3. You must retain your bill of sale or other proof of purchase to receive warranty service.
4. No warranty extension will be granted for any replacement part(s) furnished to the purchaser in fulfillment of this warranty.